

### Description:

- 20 gauge, 18-10 stainless steel, type 304
- **Large bowl** - 16 x 14, 7" deep  
(41 x 36 cm, 18 cm deep)
- **Small bowl** - 16 x 10-3/8, 7" deep  
(41 x 26 cm, 18 cm deep)
- **Overall size** - 20 1/2 x 28, 7" deep  
(52 x 71, 18 cm deep)
- Rear drain location
- Self-rimming with faucet ledge and lower centre bar to avoid spillage
- Brush finished bowls, mirror finished rim

### Recommended minimum cabinet width:

- 30"

### Faucet hole drilling:

- 3 holes - 1 1/2" diameter, 4" centre-to-centre (ECL2028-7-3)
- 1 hole on centre (ECL2028-7-1)

### Inclusions:

- Basket strainer: EA-114
- Undercoating and sound deadening pads
- Template
- Hold-down clips
- All sinks individually boxed

### Optional Accessories:

- Stainless steel bottom grid with rubber feet:  
Large bowl **EBGD1614**. Small bowl **EBGD1610**.
- Stainless steel countertop roll mat with silicone wrapped bars: **ERM1814**
- Hardwood countertop cutting board: **ECB1810**
- **Reference document available:**  
*Excalibur Sink Cross Reference to Accessories*

### Certifications:

- Sinks CUPC certified by IAPMO, strainers certified by CSA

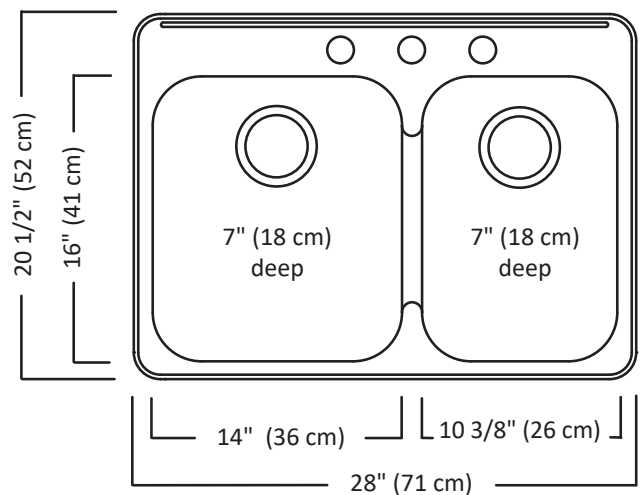

ECB1810  
Countertop  
Cutting Board

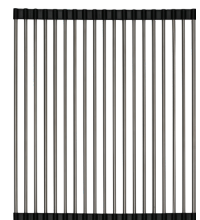

ERM1814  
Countertop  
Roll Mat



EBGD1614  
Bottom Grid



EBGD1610  
Bottom Grid

