

Description:

- 18 gauge, 18-10 stainless steel, type 304
- **Two equal bowls** - 16 x 14, 8" deep (41 x 35, 20 cm deep)
- **Overall size** - 20 1/2 x 31 1/4, 8" deep (52 x 80, 20 cm deep)
- Rear drain location
- 10 mm radius corners
- 2" low divide centre separation
- Creased lines on bottom to improve drainage
- Self-rimming with faucet ledge
- Satin bowl and deck

Faucet hole drilling:

- 3 holes, 1 1/2" diameter, 4" centre-to-centre: (EDLF2031-8-LD-3)
- 4 holes, 1 1/2" diameter, 4" centre-to-centre: (EDLF2031-8-LD-4)
- 1 hole on centre, 1 1/2" diameter: (EDLF2031-8-LD-1)

Recommended minimum cabinet width:

- 33"

Inclusions:

- Basket strainer: EA-114
- Undercoating and sound deadening pads
- Template
- Hold-down clips
- All sinks individually boxed

Optional Accessories:

- Stainless steel bottom grid with rubber feet: **EBGF1614** fits either bowl
- Stainless steel countertop roll mat with silicone wrapped bars: **ERM1814**
- Hardwood countertop cutting board: **ECB1810**
- **Reference document available:**
Excaltibur Sink Cross Reference to Accessories

Certifications:

- Sinks CUPC certified by IAPMO, strainers certified by CSA

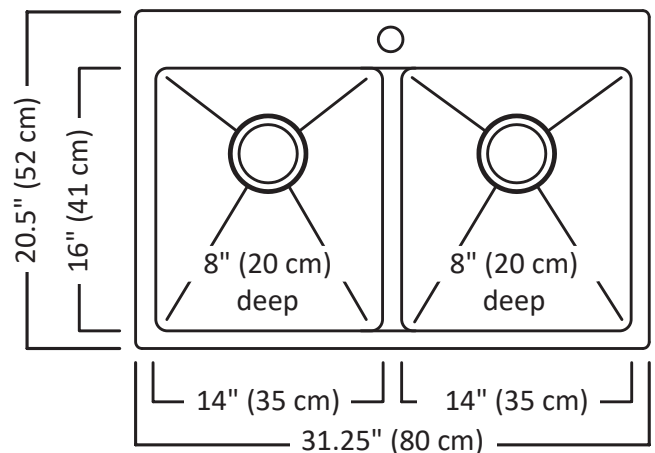

ECB1810
Countertop
Cutting Board

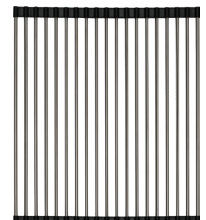

ERM1814
Countertop
Roll Mat

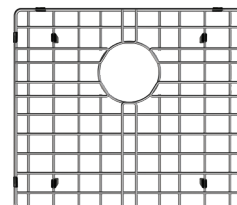

EBGF1614
Bottom Grid

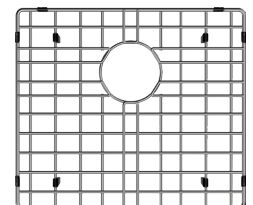

EBGF1614
Bottom Grid

