

Description:

- 18 gauge, 18-10 stainless steel, type 304
- **Single bowl** - 16 x 28 1/2, 9" deep
(41 x 72 cm, 23 deep)
- **Overall size** - 18 1/2 x 30 1/2, 9" deep
(47 x 77, 23 cm deep)
- Rear drain location
- Brush finished bowl, mirror polished rim

Recommended minimum cabinet width:

- 33"

Inclusions:

- Basket strainer: EA-114
- Undercoating and sound deadening pads
- Template
- Installation clips
- All sinks individually boxed

Optional Accessories:

- Stainless steel bottom grid with rubber feet:
EBGD1628
- Stainless steel countertop roll mat with silicone wrapped bars: **ERM1814**
- Hardwood countertop cutting board:
ECB1810
- **Reference document available:**
Excalibur Sink Cross Reference to Accessories

Certifications:

- Sinks CUPC certified by IAPMO, strainers certified by CSA

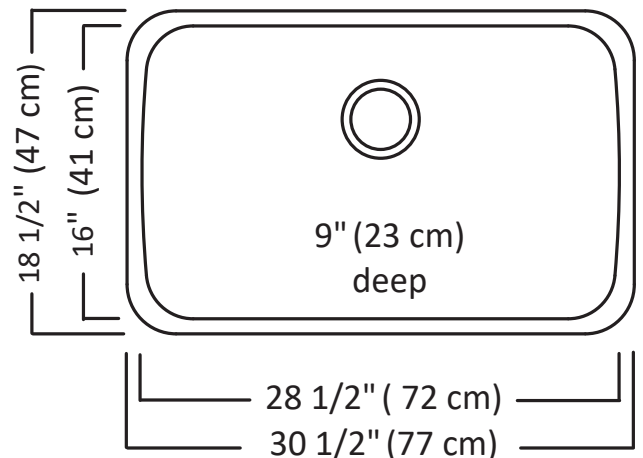

ECB1810
Countertop
Cutting Board

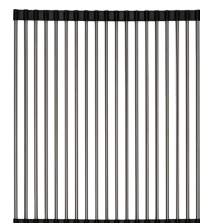

ERM1814
Countertop
Roll Mat

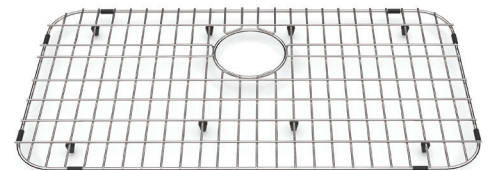

EBGD1628 Bottom Grid

