

### Description:

- Apron Front Sink
- 18 gauge, 18-10 stainless steel, type 304
- **Two equal bowls** - 16 x 14, 9" deep (41 x 36, 23 cm deep)
- **Overall size** - 20 3/4 x 32 3/4, 9" deep (53 x 83, 23 cm deep)
- 10 mm radius corners
- Flat front apron
- Rear drain waste hole location
- 2" low divide centre separation to avoid spillage
- Creased bottom for improved drainage
- Undercoating and sound deadening pads
- Satin finished bowl, deck and apron front

### Recommended minimum cabinet width:

- 33"

### Inclusions:

- Basket strainer: EA-114
- Undercoating and sound deadening pads
- Template
- All sinks individually boxed

### Optional Accessories:

- Stainless steel bottom grid with rubber feet: **EBGF1614** fits either bowl
- Stainless steel countertop roll mat with silicone wrapped bars: **ERM1814**
- Hardwood countertop cutting board: **ECB1810**
- **Reference document available:**  
*Excalibur Sink Cross Reference to Accessories*

### Certifications:

- Sinks CUPC certified by IAPMO, strainers certified by CSA

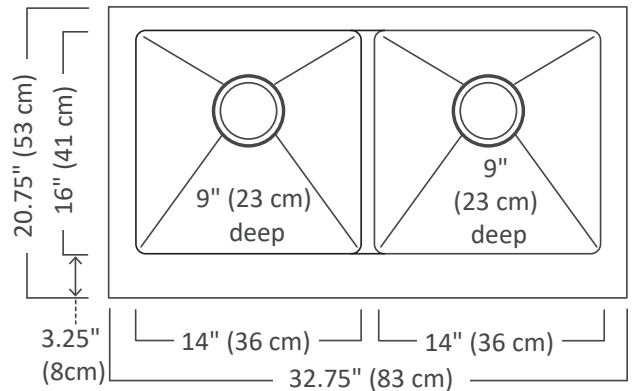

ECB1810  
Countertop  
Cutting Board

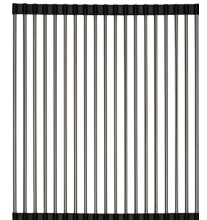

ERM1814  
Countertop  
Roll Mat

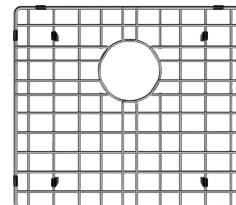

EBGF1614  
Bottom Grid

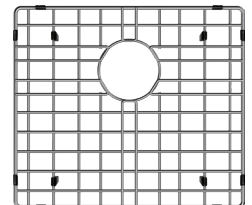

EBGF1614  
Bottom Grid

