



Description:

- Aspire 16 Accessorized Sink
- 16 gauge, 18-10 stainless steel, type 304
- **Large bowl** - 16 1/4 x 17", 9 1/2" deep (41 x 43 cm, 24 cm deep)
- **Small bowl** 16 1/4 x 10, 9 1/2" deep (41 x 25 cm, 24 cm deep)
- **Overall size** - 18 1/4 x 30, 9 1/2" deep (46 x 76, 24 cm deep)
- 10 mm radius corners
- Rear drain location
- 2" low divide centre separation
- Creased lines on bottom to improve drainage
- Satin bowl and ledge

Recommended minimum cabinet width:

- 33"

Inclusions:

- EB-114 deep basket strainer
- Undercoating and sound deadening pads
- Template
- Installation clips
- All sinks individually boxed
- Special X-pattern bottom grids
- Stainless steel utility rack

Certifications:

- Sinks and strainers CUPC certified through IAPMO

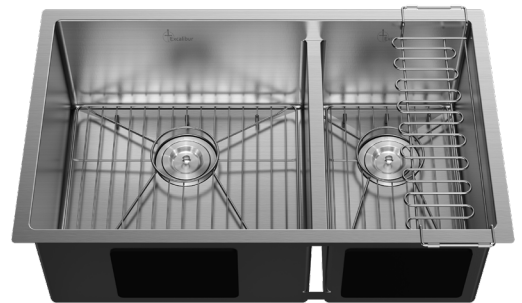

Shown with all included accessories

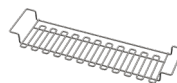
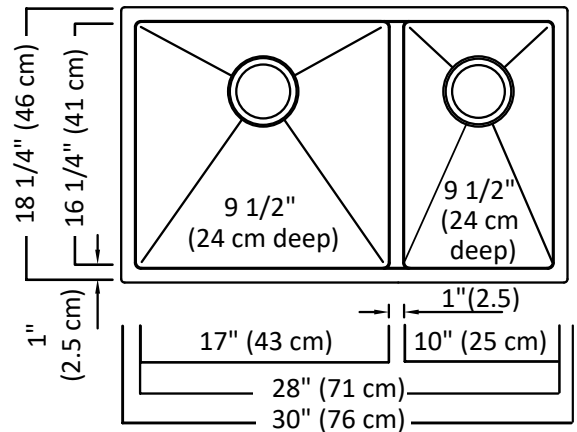

Utility Rack



Strainer

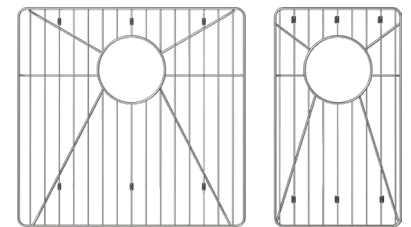

Bottom Grids