

Description:

- 18 gauge, 18-10 stainless steel, type 304
- **Bowl size** - 17 x 23, 8" deep
(43 x 58, 20 cm deep)
- **Overall size** - 22 x 25, 8" deep
(56 x 64, 20 cm deep)
- Rear drain location
- 10mm radius corners
- Creased lines on bottom to improve drainage
- Self-rimming with faucet ledge
- Satin bowl and deck

Faucet hole drilling:

- 3 holes, 1 1/2" diameter, 4" centre-to-centre: (ESLF2225-8-3)
- 4 holes, 1 1/2" diameter, 4" centre-to-centre: (ESLF2225-8-4)
- 1 hole, on centre, 1 1/2" diameter: (ESLF2225-8-1)

Recommended minimum cabinet width:

- 27"

Inclusions:

- Basket strainer: EA-114
- Undercoating and sound deadening pads
- Template
- Hold-down clips
- All sinks individually boxed

Optional Accessories:

- Stainless steel bottom grid with rubber feet: **EBGF1723**
- Stainless steel countertop roll mat with silicone wrapped bars: **ERM1914**
- Hardwood countertop cutting board: **ECB1910**
- **Reference document available:**
Excalibur Sink Cross Reference to Accessories

Certifications:

- Sinks CUPC certified by IAPMO, strainers certified by CSA

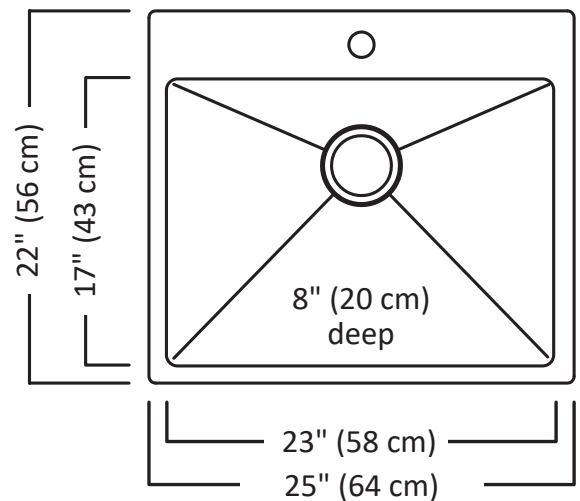

ECB1910
Countertop
Cutting Board

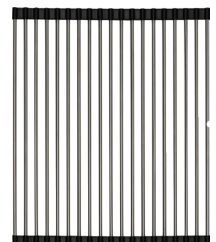

ERM1914
Countertop
Roll Mat

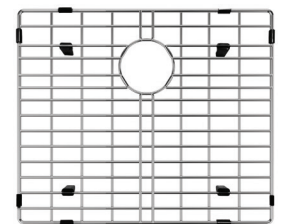

EBGF1723 Bottom Grid

