

Description:

- 18 gauge, 18-10 stainless steel, type 304
- **Two equal bowls** - 16 x 14, 8" deep (41 x 46, 18 cm deep)
- **Overall size** - 17 3/4 x 31 1/4, 7" deep (45 x 79, 18 cm deep)
- Rear drain location
- Brush finished bowls, mirror polished rim
- Lowered centre bar to prevent spillage

Recommended minimum cabinet width:

- 33"

Inclusions:

- Basket strainer: EA-114
- Undercoating and sound deadening pads
- Template
- Installation clips
- All sinks individually boxed

Optional Accessories:

- Stainless steel bottom grids with rubber feet: **EBGD1614** fits either bowl
- Stainless steel countertop roll mat with silicone wrapped bars: **ERM1814**
- Hardwood countertop cutting board: **ECB1810**
- **Reference document available:**
Excalibur Sink Cross Reference to Accessories

Certifications:

- Sinks CUPC certified by IAPMO, strainers certified by CSA

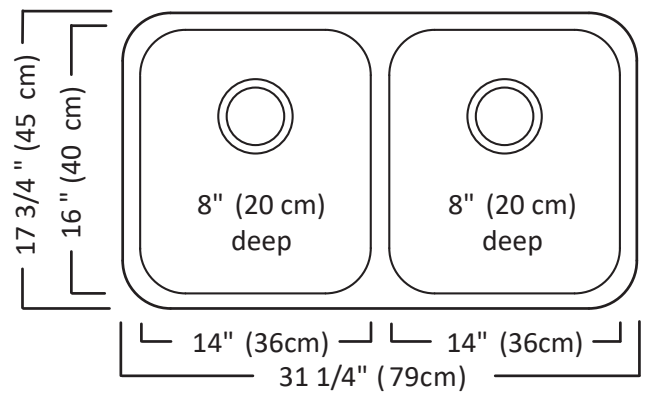

ECB1810
Countertop
Cutting Board

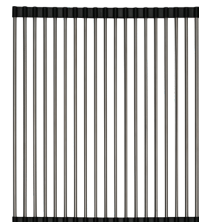

ERM1814
Countertop
Roll Mat

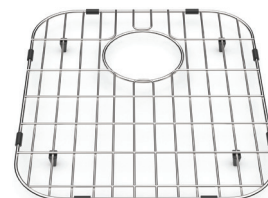

EBGD1614
Bottom Grid



EBGD1614
Bottom Grid

